

IID

S

SERIES
SC-35

DURA-BILT® COMPACTORS



Self Contained

The cost saving of solid waste compaction in limited space applications is a today fact.

Only 200 sq. ft. are required for the placement of a Dura-Bilt Space Squeezer Compactor. In limited space areas, the SC-35 can be picked up from either end.

The unique cylinder cycle arrangement in the SC-35 now means larger container capacity and bigger hopper space for the benefit of the customer.

Job Designed... Application Sized for:

- Malls
- Restaurants
- In-Flight Kitchens
- Hospitals
- Schools
- Apartment Complexes
- Hotels
- Food Processors

User Benefits of the Dura-Bilt Space Squeezer Compactor:

- Liquid tight—for improved odor and insect control
- Maximum compaction in minimum space
- Provides capacity for weekends, holidays, and season changes
- Low cost installation
- Improved housekeeping
- Fire resistant
- Reduces opportunity for back-door pilferage
- Easy loading—simple key operation
- Reduces exposure to pavement damage

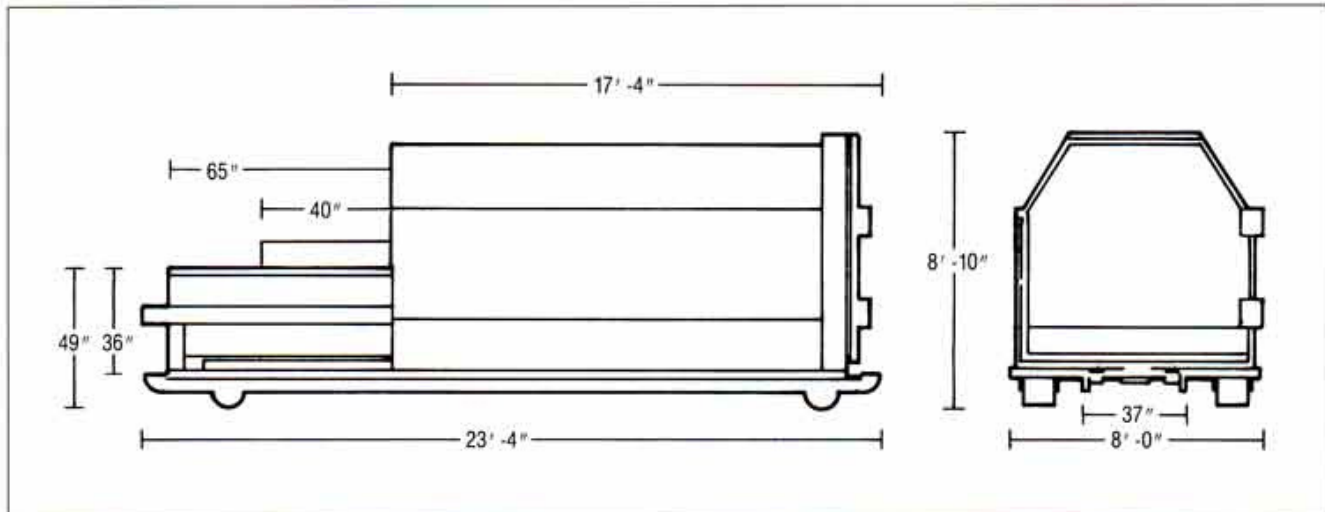

SC-35 DURA-BILT COMPACTORS

SPECIFICATIONS

| | |
|--|--|
| Hopper capacity | 2 cubic yards |
| Container capacity | 35 cubic yards |
| Charge box opening | 40 x 60 inches |
| Loading height from platform | 37 inches |
| Loading height from ground | 49 inches |
| Weight | 10,400 lbs. |
| Cycle time | 29 seconds |
| Normal operating pressure | 1600 lbs. PSI |
| Maximum operating pressure | 2000 lbs. PSI |
| Packing pressure per square inch (PSI) | 29 lbs. PSI |
| Total compaction force | 31,400 lbs. |
| Cylinder size (2) | Double cylinders/4 inches each |
| Cylinder stroke | 32 inches |
| Ram penetration | 15 inches w/packer wedge |
| Hydraulic pump | 12 GPM |
| Electric motor | 10 HP 208—230/460V 3-phase 60 cycle—High Torque Tri-Voltage |
| Control circuit | 110V computer controlled |

**Nationwide installations
custom-fitted to any user requirements**

Design and specifications subject to change without notice.

Optional Equipment

- Side or dock hopper
- Dock ramp
- Safety hand rails and end gate
- Side or rear opening thru-wall-chute with security door
- Fully enclosed dog house—with door
- Fluid filled pressure gauge
- Cart dumper and carts
- Oil immersion heater
- Deodorizer system



Heavy-duty ratchet latching mechanism aids water tight sealing of both sides of rear door



Unique rear door design and extra-heavy hinges insure long maintenance-free life of the Dura-Bilt Space Squeezer Compactor



Pressure Switch Power Unit for Simplicity. Tri-Voltage Power Supply-208, 230 or 460 Volt 3 Phase. 100% Full Container Light.

CAUTION!
THIS COMPACTOR
STARTS AND STOPS
REMOTELY

¡CUIDADO!
ESTE COMPACTADOR
IMPIEZA Y PARA
REMOTAMENTE

Bilingual safety decals are provided to meet current A.N.S.I. standards.



INDUSTRIAL DISPOSAL SUPPLY COMPANY

San Antonio
P.O. Box 8175
78208
210/227-3441
Fax 210/227-4424

Houston
P.O. Box 8623
77249
713/692-7289
Fax 713/692-7996

Plano (Dallas)
P.O. Box 860707
75086
214/423-1423
Fax 214/424-7203